

# Detection of Pneumothorax Visualized by Computer Analysis of Bilateral Respiratory Sounds

Nobuhiro Hayashi

*Division of Emergency and Disaster Medicine, Department of Surgery, School of Medicine, Tottori University Faculty of Medicine, Yonago 683-8504, Japan*

**Pneumothorax is usually diagnosed based on the attenuation of respiratory sounds of the affected side on auscultation, but it requires a skilled technique and is limited to subjective evaluation. Thus, we designed a device which analyzes and converts the frequency of auscultatory sounds to numerical values with a computer. With this device, the bilateral sound pressure levels were compared between groups of 25 healthy subjects and 21 patients with pneumothorax to investigate the efficacy of the diagnosing tool of pneumothorax. While recording respiratory sounds of the bilateral precordial regions, the fast Fourier transform was applied with a frequency analysis software, power spectra of the auscultatory sounds were displayed in real-time, and the sound pressure level was compared between the bilateral sides. The difference was investigated at frequencies judged as less likely to be influenced by cardiac sounds (200–400 Hz). No difference was observed in the control group ( $n = 25$ ,  $P > 0.05$ ), but respiratory sound attenuation was detectable on the affected side in the pneumothorax group ( $n = 21$ ,  $P < 0.01$  each for the paired Student's  $t$ -test and Wilcoxon signed-rank test). When the cutoff value was 8 dB, the sensitivity and specificity as diagnostic tool of pneumothorax was 71.4% and 100%, respectively. This device would facilitate the detection of occult pneumothorax at accident scenes, in emergency rooms and in intensive care units.**

**Key words:** fast Fourier transform; frequency analysis; pneumothorax; real-time monitor

Although auscultation is an essential diagnostic method, it has become underestimated in many cases as healthcare and medicine have advanced (Miyahara et al., 2005). However, it is a simple, noninvasive, quick diagnostic technique and is appropriate to rapidly investigate the pathological condition, and is still very useful for medical care in emergencies and disasters (Hiraide and Iwami, 2001). Making a diagnosis based on auscultation requires sufficient experience, lacking objectivity, and sharing and recording of the information are difficult (Murata et al., 2000). I designed a record analysis device which presents changes in the

pressure of respiratory sounds as waveforms, and applied it to healthy subjects and pneumothorax patients. The aim of this study was to evaluate the difference of respiratory sounds objectively by recording the sound pressure at appropriate frequencies, and to investigate the sensitivity and specificity of the device.

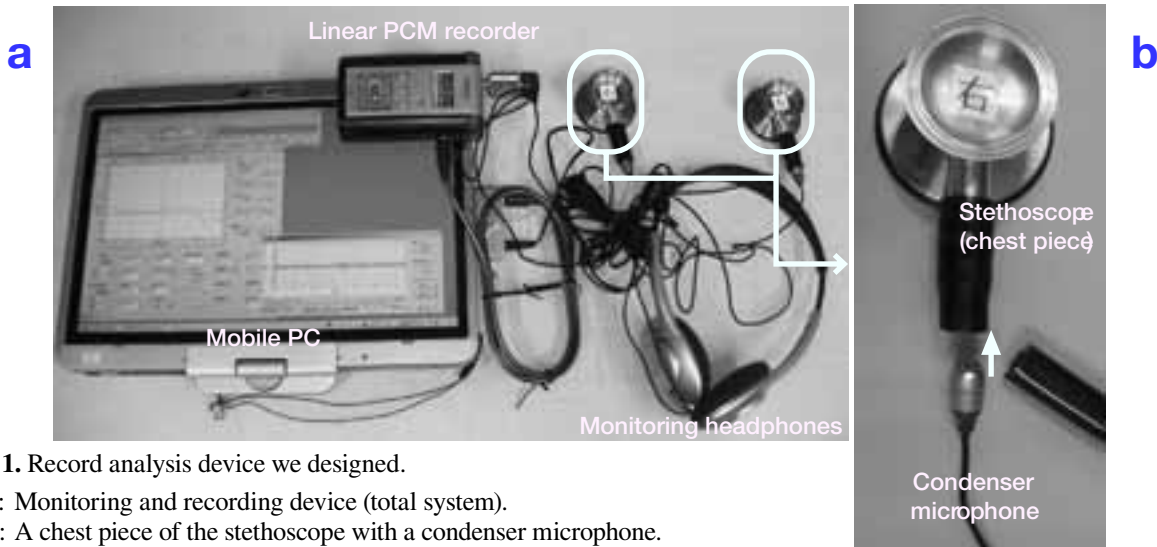
## Materials and Methods

Two sets of a membrane-type stethoscope (Littmann Cardiology III, 3M, St. Paul, MN) connected to a

---

Abbreviations: CT, computed tomography; FFT, fast Fourier transform; PC, personal computer

Present address: Clinical Department of Emergency and Critical Care Medicine, Juntendo University Urayasu Hospital, 2-1-1 Tomioka, Urayasu 279-0021, Japan

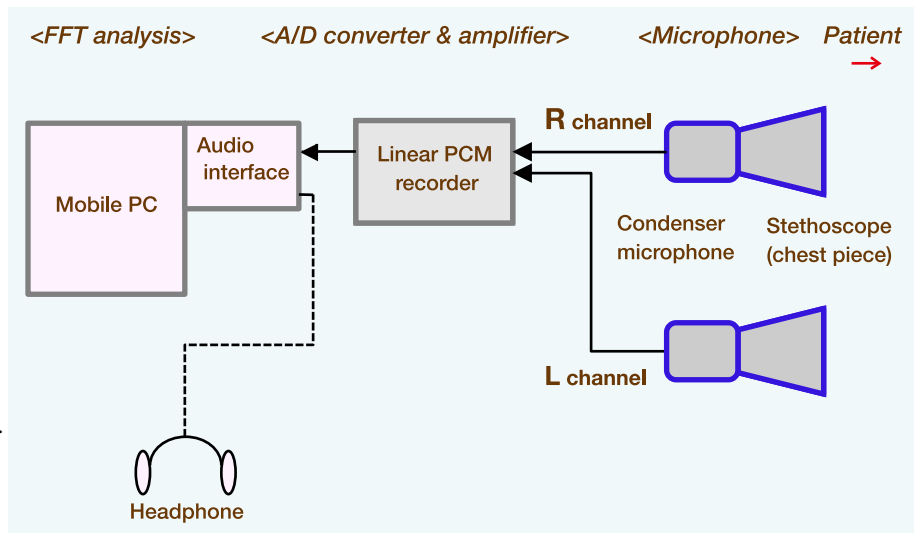


**Fig. 1.** Record analysis device we designed.

a: Monitoring and recording device (total system).

b: A chest piece of the stethoscope with a condenser microphone.

PC, personal computer; PCM, pulse code modulation.



**Fig. 2.** Block diagram.

A/D, analog-to-digital;

FFT, fast Fourier transform;

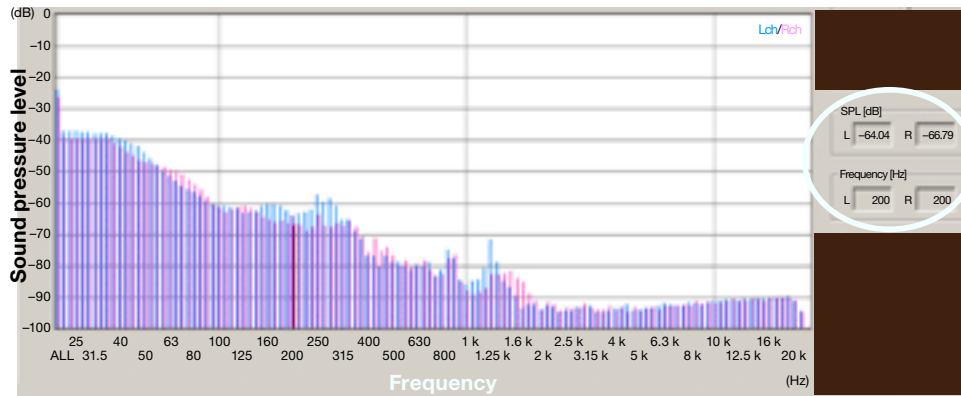
PC, personal computer;

PCM, pulse code modulation.



**Fig. 3.** Recording set-up. A pair of chest pieces is placed in the bilateral second intercostal spaces on the midclavicular line.

condenser microphone (ECM-C10, SONY, Tokyo, Japan) were prepared (Fig. 1a), and respiratory sounds were input into a mobile personal computer (PC) via a linear pulse code modulation recorder (EDIROL R-09, Roland, Hamamatsu, Japan) and sound card (Creative Sound Blaster X-Fi Xtreme Audio Notebook, Creative Technology, Singapore) (Figs. 1b and 2). Quantization was performed at 16 bits and 48 kHz. The bilateral inputs were subjected to the fast Fourier transform (FFT) using a frequency analysis software (Realtime Analyzer version 5, Yoshimasa Electronic, Tokyo, Japan), and the power spectrum waveform of the input information was compared between the bilateral sides (FFT size: 4096, smoothing: Hanning window at a

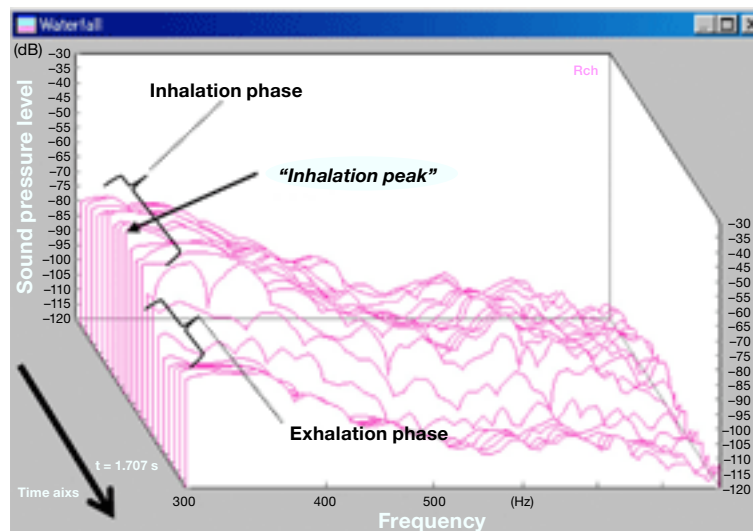


**Fig. 4.** A sample of power spectra monitored on the mobile personal computer. Using this frequency analysis software, we can measure the sound pressure level (dB) of the left and right inputs at the arbitrary time phase and the arbitrary frequency (circled). The generated value is negative, because the maximum input is processed from 0. The X axis (frequency) is displayed on the logarithmic scale. Lch, left channel; Rch, right channel.

time constant of 125 ms, frequency weighting: flat). The recording sites were symmetrically arranged in the bilateral second intercostal spaces on the midclavicular lines, and respiratory sounds were heard with headphones (Fig. 3). The chest pieces of the stethoscopes were put on the chest wall by own dignity without hands and fixation to avoid noise artifacts. The chest piece was lightly fixed to the chest wall with paper tape for subjects with a hairy chest or with well-formed pectoral muscles. This frequency analysis software is capable of extracting sound pressure levels at a specific frequency, but

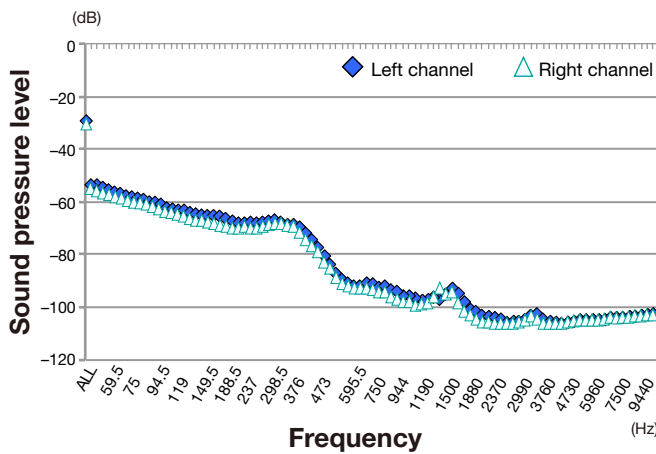
the sound pressure levels are presented as negative values (relative values), regarding the maximum input that the PC can process as 0 (Fig. 4). All recordings were performed after obtaining informed consent from the subjects. The present study was reviewed by the Ethical Review Board of Juntendo University Urayasu Hospital.

All subjects spontaneously breathed, and the recording was performed in the emergency room or in the intensive care unit. Although 1-cycle breathing (a few seconds) was also possible for this analysis, about 10 cycles per patient were recorded.

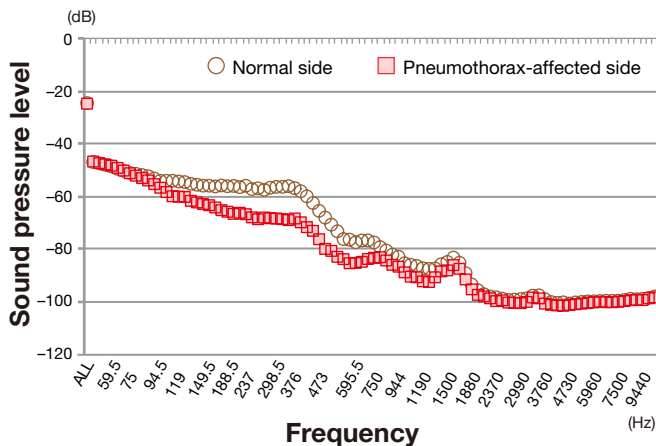


**Fig. 5.** Three-dimensional (waterfall) display of normal respiratory sounds as spectrograms of typical respiratory sounds in the 300–900 Hz frequency band. Two peaks are shown. The 1st (posterior) peak corresponds to the inspiration phase, and the 2nd (anterior), to the expiration phase. Rch, right channel.

Subjects with no chest trauma or respiratory disease were defined as normal, showing clear respiratory sounds without laterality or abnormality on chest X-ray examination. Twenty-five healthy subjects underwent recording, and served as the control group. In the frequency distribution of normal respiratory sounds, the sound pressure levels in the 200–400 Hz range are less influenced by cardiac sounds (Ishigaki et al., 1993). Thus, the difference was investigated at the following frequencies: 200, 211.5, 224, 237, 250, 266, 282, 298.5, 315, 335, 355, 376 and 400 Hz which were 1/12 octave-band, based on the interval of logarithmic scales. The spectrum was observed over time, as shown in



**Fig. 6.** Mean sound pressure levels from the left and right channels in the control group ( $n = 25$ ) at the inhalation peak time point.



**Fig. 7.** Mean sound pressure levels of the normal and affected sides of the pneumothorax group ( $n = 21$ ) at the inhalation peak time point. The attenuation of the sound pressure on the affected side is shown in the 119–750 Hz frequency band.

**Table 1. Clinical characteristics of pneumothorax patients [n = 21]**

Age (yr)	
Mean $\pm$ SD	46.1 $\pm$ 19.2
Range	18 – 83
Gender	
Male	17 (81%)
Female	4 (19%)
Traumatic	12
Motor vehicle accident	10
Fall	2
Non-traumatic	9
Spontaneous	8
Chronic obstructive pulmonary disease	1

Fig. 5, and the time phase with the maximum wave (consistent with the inhalation peak flow) was determined as the “inhalation peak time point”.

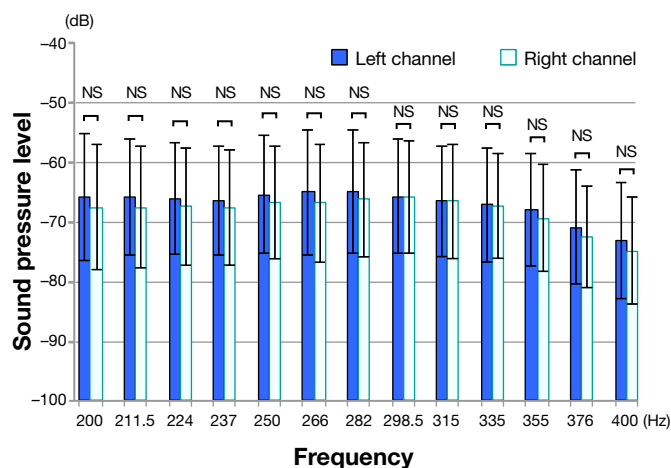
In the control group ( $n = 25$ , 19 males and 6 females: mean age 45.2 years, range 28–70 years), the sound pressure levels of the bilateral inputs at the inhalation peak time point were divided into 2 subgroups of the left and right sides, and the differences between the mean bilateral values were analyzed. Of patients who visited Emergency and Critical Care Medical Center of Tottori University Hospital between August 2008 and March 2009 and Clinical Department of Emergency and Critical Care Medicine of Juntendo University Urayasu Hospital between June 2010 and March 2011, 21 were diagnosed as pneumothorax by X-ray or computed tomography (CT) of the chest. Twelve of them were traumatic and 9 were non-traumatic (Table 1). No traumatic patients had head injury. There was no medical history of asthma. All traumatic patients had oxygen administration according to the prehospital protocol. One non-traumatic patient with chronic obstructive pulmonary disease developed hypercapnia. In the pneumothorax group ( $n = 21$ ), the bilateral inputs were divided into 2 subgroups of the normal

and pneumothorax-affected sides, and the differences between the mean values were analyzed.

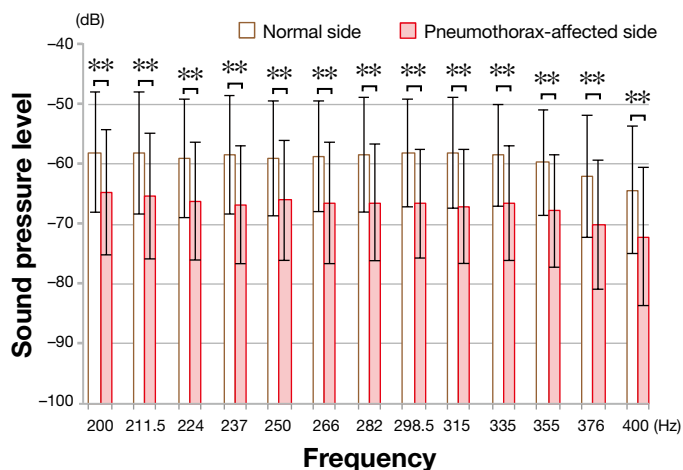
The statistical significances of differences in sound pressure levels between the left and right-side subgroups for the control group and between the normal and affected-side subgroups for the pneumothorax group were determined by the paired *t*-test and Wilcoxon signed-ranks test. The accepted level of significance was  $P < 0.05$ . Twenty-one patients ( $n = 20.87$ ) as the minimum sample size for a *t*-test was required to attain a  $\beta$  value  $\geq 0.8$  from the result of the power analysis.

## Results

Mean sound pressure levels at the inhalation peak time point from bilateral channels in the control group were plotted in the 50–1000 Hz frequency band on the logarithmic scale (Fig. 6). Almost the identical forms were confirmed in the control group. In the pneumothorax group, mean sound pressure levels at the inhalation peak time point were plotted from the normal and affected sides in the 50–1000 Hz frequency band on the logarithmic scale (Fig. 7). The sound pressure level was attenuated on the affected side in the 119–750 Hz range. The difference was examined in the 200–400 Hz range, where the attenuation was especially large. In the control group ( $n = 25$ ), differences were not significant between both inputs at all frequencies in the 200–400 Hz range (Fig. 8). In the pneumothorax group ( $n = 21$ ), differences were significant between the normal and affected sides at all frequencies in the 200–400 Hz range ( $P < 0.01$ ) (Fig. 9). A non-parametric test (Wilcoxon signed-ranks test) also showed the same results as above. When the cutoff value (the difference between the



**Fig. 8.** Sound pressures compared between the left and right channels in the control group ( $n = 25$ ). NS, not significant:  $P > 0.05$  (paired *t*-test and Wilcoxon signed-rank test).



**Fig. 9.** Sound pressure levels show significant differences between the normal and affected sides of patients of the pneumothorax group ( $n = 21$ ).  $**P < 0.01$  (paired *t*-test and Wilcoxon signed-rank test).

normal and affected sides) was 8 dB, the best sensitivity and specificity of this device were 71.4 % (at 315 Hz) and 100 % (at 250 and 298.5 Hz), respectively (Table 2).

## Discussion

The presently introduced device visualizes the sound pressure level to detect pneumothorax. By the frequency analysis of respiratory sounds of pneumothorax patients, I found that the difference

**Table 2. Sensitivity and specificity of the present device at frequencies examined in the 200–400 Hz range**

	Frequency (Hz)													
	200	211.5	224	237	250	266	282	298.5	315	335	355	376	400	
Sensitivity	47.6	61.9	66.7	66.7	57.1	57.1	52.4	57.1	71.4	61.9	52.4	40.9	42.9	
Specificity	79.2	83.3	91.7	95.8	100.0	87.5	91.7	100.0	95.8	91.7	87.5	91.7	87.5	

diagnosed by respiratory sound attenuation on the affected side could be objectively detected in waveforms at appropriate frequencies. In addition, the absence of the difference in healthy subjects was confirmed.

I selected the 200–400 Hz frequency band because the spectra of alveolar and tracheal respiratory sounds are mostly less than 500 Hz, because the power markedly decreases at a higher frequency (Ishigaki et al., 1993; Nakano et al., 1994) and because the main spectrum of cardiac sound noises is 40–200 Hz (Nakano et al., 1994; Debbal and Bereksi-Reguig, 2008). Mansy and coworkers recorded respiratory sounds using a dog model of pneumothorax on the affected side before and after the onset of pneumothorax, and observed that the the pressure level of respiratory sounds was markedly attenuated in the 200–700 Hz range (Mansy et al., 2002a). In another study of sound transmission measurement, white noise was played via a speaker connected to a tracheal tube inserted into a dog, and sound transmission was recorded with an electronic stethoscope at the chest wall. Then, the transmission was markedly attenuated in the 200–1200 Hz range (Mansy et al., 2002b). A similar tendency was noted in the present study.

I could easily use this device in the emergency room and intensive care unit in almost all situations. Even in a noisy situation, it requires only a few seconds to become calm. Although I did not study the possible limitation of this device, a question how to evaluate pneumothorax with massive subcutaneous emphysema may be raised because noise is marked in such cases. However, it becomes no subject of discussion because the existence of subcutaneous emphysema is an indirect finding of pneumothorax. Furthermore, bilateral pneumo-

thoraces are undetectable because there is little difference between both sides. In patients with postoperative pleural adhesions or adhesive pleural disease such as tuberculous pleuritis and chronic obstructive pulmonary disease, differences are also undetectable because there are no intrathoracic spaces between the stethoscope on the chest wall and ipsilateral lung parenchyma.

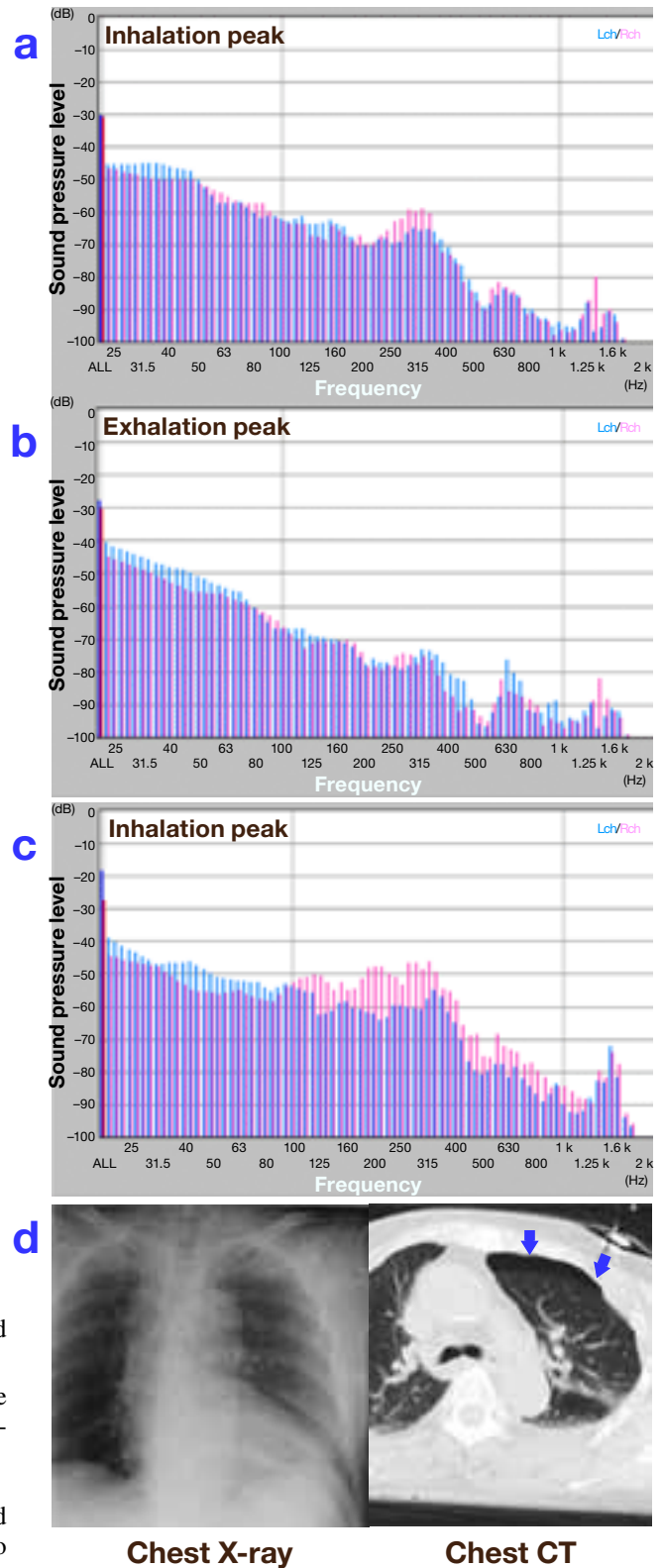
I would like to investigate the association between the pneumothorax volume and level of sound pressure attenuation. Laterality was investigated only at a single time point (inhalation peak) in the present study. But our final aim is to develop an automatic laterality-detecting program by averaging several inhalation cycles, taking advantages of the fact that the difference in sound pressure between inhalation and exhalation in pneumothorax patients is smaller than that in healthy subjects (Mansy et al., 2002a). Furthermore, I could investigate the application of the present method for hemothorax by combining an algorithm that reduces cardiac sounds and surrounding noise.

The presence of occult pneumothorax by trauma is known, which could progress to tension pneumothorax during transport or positive pressure ventilation (Rhea et al., 1989; Hill et al., 1999; Japanese Association for the Surgery of Trauma Development Committee, 2004), but occult pneumothorax is detectable only by CT scan. The sensitivity and specificity of routine supine antero-posterior chest X-ray as a diagnostic tool was 52% and 100%, respectively (Soldati et al., 2008). On the other hand, our device is more accurate as a diagnostic tool (sensitivity, 71.4%; specificity, 100%).

The representative waveforms on frequency analysis are presented in a healthy subject and a pneumothorax patient (Figs. 10a–c). Figures 10a

and b show stationary waveforms at the inhalation and exhalation phases in the healthy subject. No difference was noted between the bilateral inputs (sound pressure levels) at the inhalation peak point in the 200–400 Hz frequency band. In the waveforms of the 65-year-old female patient with chest contusion by a motor vehicle accident (Fig. 10c), pneumothorax was not observed on the initial antero-posterior X-ray examination but diagnosed by CT scan showing left occult pneumothorax (Fig. 10d). Only an instructor physician with abundant experience could identify the difference of respiratory sounds in the emergency room, and the distinction was so subtle that residents and nurses recorded it as no difference, but the device could detect the waveform attenuation of left respiratory sounds around 200 to 400 Hz in waveforms.

Reportedly, thoracic drainage is necessary for about 20% of patients with occult pneumothorax (Livingston and Hauser, 2008). For such patients, continuous monitoring with the present device may detect changes in the pathological condition in an early stage. Recently, a digital signal processing equipment which subtracts the sound wave of surrounding noise from the total input sound has spread, and it is used for headphones and digital hearing aids. If these noise reduction technologies are combined in the future, the present device may be useful as a low-cost, light and compact mobile respiratory



**Fig. 10.** Representative waveforms and images recorded from a healthy control and a pneumothorax patient.

**a:** Waveforms of the control at the inhalation peak time point. No difference is recognized between the bilateral channels in the 200–400 Hz range.

**b:** Waveforms of the control at the exhalation phase.

**c:** Waveforms at the inhalation peak of the 65-year-old female patient with left occult pneumothorax due to a motor vehicle accident. The difference between the bilateral channels is visually recognized in the 200–400 Hz range.

**d:** Images by supine antero-posterior chest X-ray (left) and chest CT (right) of the patient. Only the front part of the left lung is marginally collapsed (arrows).

CT, computed tomography; Lch, left channel; Rch, right channel.

monitor equipped in ambulances, for remote medical care, and as an educational material.

With a newly designed record analysis device which visualizes changes in the respiratory sound pressure as waveforms, difference in respiratory sound attenuation on the pneumothorax-affected side could be objectively detected in the waveforms of pneumothorax patients. The device is easily applicable without any skill in the emergency room.

### References

- 1 Debbal SM, Bereksi-Reguig F. Computerized heart sounds analysis. *Comput Biol Med* 2008;38:263–80.
- 2 Hill SL, Edmisten T, Edmisten T, Holtzman G, Wright A. The occult pneumothorax An increasing diagnostic entity in trauma. *Am Surg* 1999;65:254–258.
- 3 Hiraide A, Iwami T. Percussion, auscultation. *Kyukyū Igaku* 2001;25:1143–1149 (in Japanese).
- 4 Ishigaki N, Kawasiro T, Abe T, Kikuchi K, Yonemaru M. CD ni yoru choshin toreiningu [Training of auscultation using CD: respiratory sound version, augmented edition.] Tokyo: Nankodo; 1993. p.19–26, p.56–58 (in Japanese).
- 5 Japanese Association for the Surgery of Trauma Development Committee of the training course for trauma. Thoracic injury. In: Primary care guideline for trauma JATEC. 2nd rev. ed. Tokyo: Herusu Shuppan; 2004. p. 69–91 (in Japanese).
- 6 Livingston DH, Hauser CJ. Trauma to the chest wall and lung. In: Feliciano DV, Mattox KL, Moore EE, eds. *Trauma*. 6th ed. New York: McGraw-Hill; 2008. p. 525–552.
- 7 Mansy HA, Royston TJ, Balk RA, Sandler RH. Pneumothorax detection using computerized analysis of breath sounds. *Med Biol Eng Comput* 2002a;40:526–532.
- 8 Mansy HA, Royston TJ, Balk RA, Sandler RH. Pneumothorax detection using pulmonary acoustic transmission measurements. *Med Biol Eng Comput* 2002b;40:520–525.
- 9 Miyahara S, Tanaka K, Funayama M, Kiyasu S, Soda H, Oka M, et al. Lung sounds analysis using electronic stethoscope. *Yakuri To Rinsho* 2005;15:511–518 (in Japanese with English abstract).
- 10 Murata A, Kudoh S, Takasaki Y, Shibuya A, Muratake T, Nakajima M. The newly developed phononeumograph. *Yakuri To Rinsho* 2000;10:355–361 (in Japanese with English abstract).
- 11 Nakano H, Sano K, Maekawa J, Narita N. Relationship between power spectra of breath sounds and inspiratory flows at different frequencies. *Nippon Kokyūki Gakkai Zasshi* 1994;32:1142–1148 (in Japanese).
- 12 Rhea JT, Novelline RA, Lawrason J, Sacknoff R, Oser A, et al. The frequency and significance of thoracic injuries detected on abdominal CT scans of multiple trauma patients. *J Trauma* 1989;29:502–505.
- 13 Soldati G, Testa A, Sher S, Pignataro G, Sala ML, Silveri NG. Occult traumatic pneumothorax: diagnostic accuracy of lung ultrasonography in the emergency department. *Chest* 2008;133:204–211.

*Received September 20, 2011; accepted October 17, 2011*

*Corresponding author: Nobuhiro Hayashi*